

DIAGRAMMA DELLE PORTATE (t)
 CAPACITY DIAGRAM (t)
 TRAGLASTDIAGRAMM (t)
 LASTENDIAGRAM (t)
 TABLEAU DES CHARGES (t)
 DIAGRAMA DE LAS CARGAS (t)

JMG

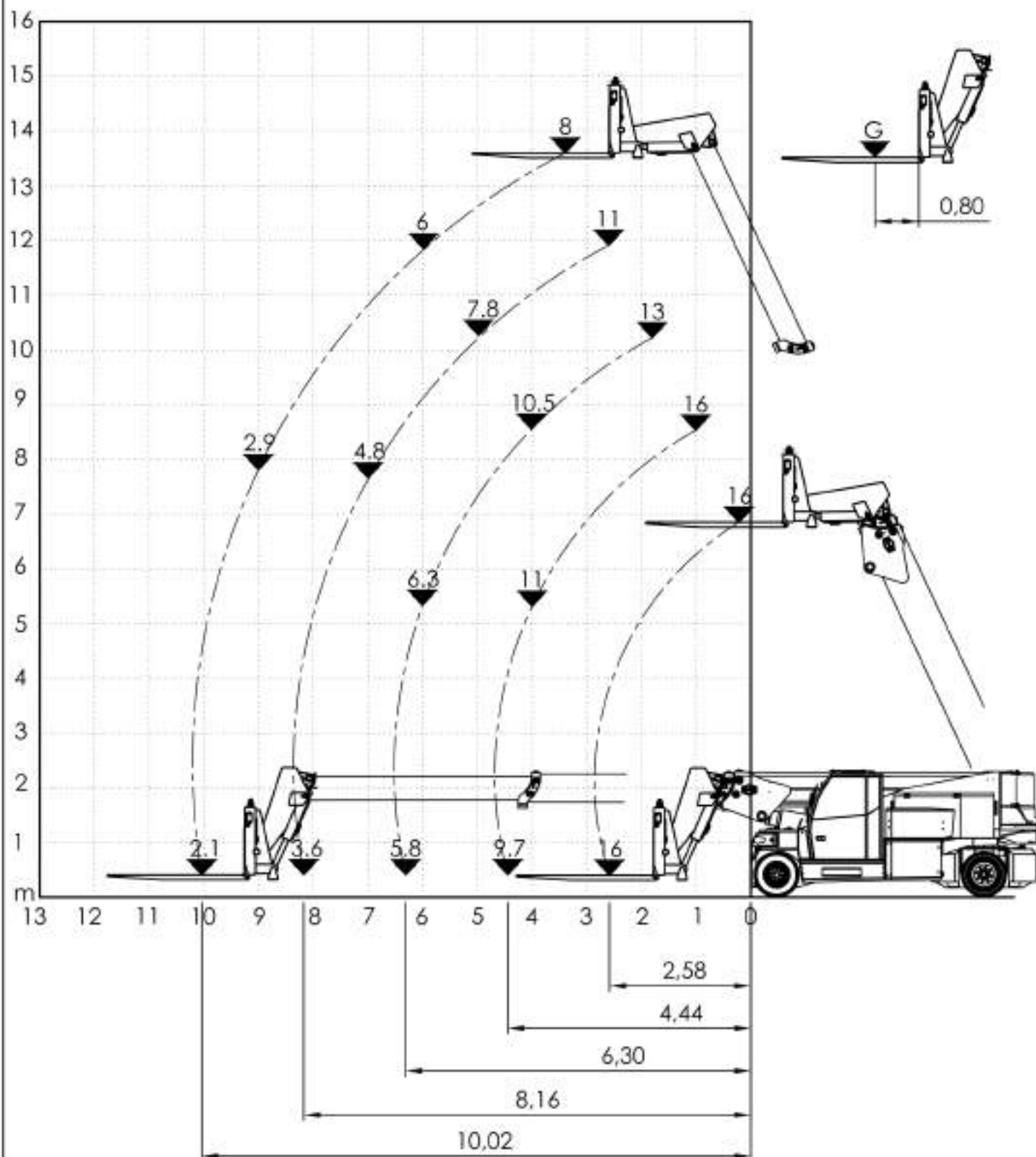

MC 400

Z1+Z2+Z3+Z4+Z5+Z6

Cod.: 090-DIA-03670

Scala: 1:100

DIAGRAMMA DELLE PORTATE (t)
 CAPACITY DIAGRAM (t)
 TRAGLASTDIAGRAMM (t)
 LASTENDIAGRAM (t)
 TABLEAU DES CHARGES (t)
 DIAGRAMA DE LAS CARGAS (t)

JMG

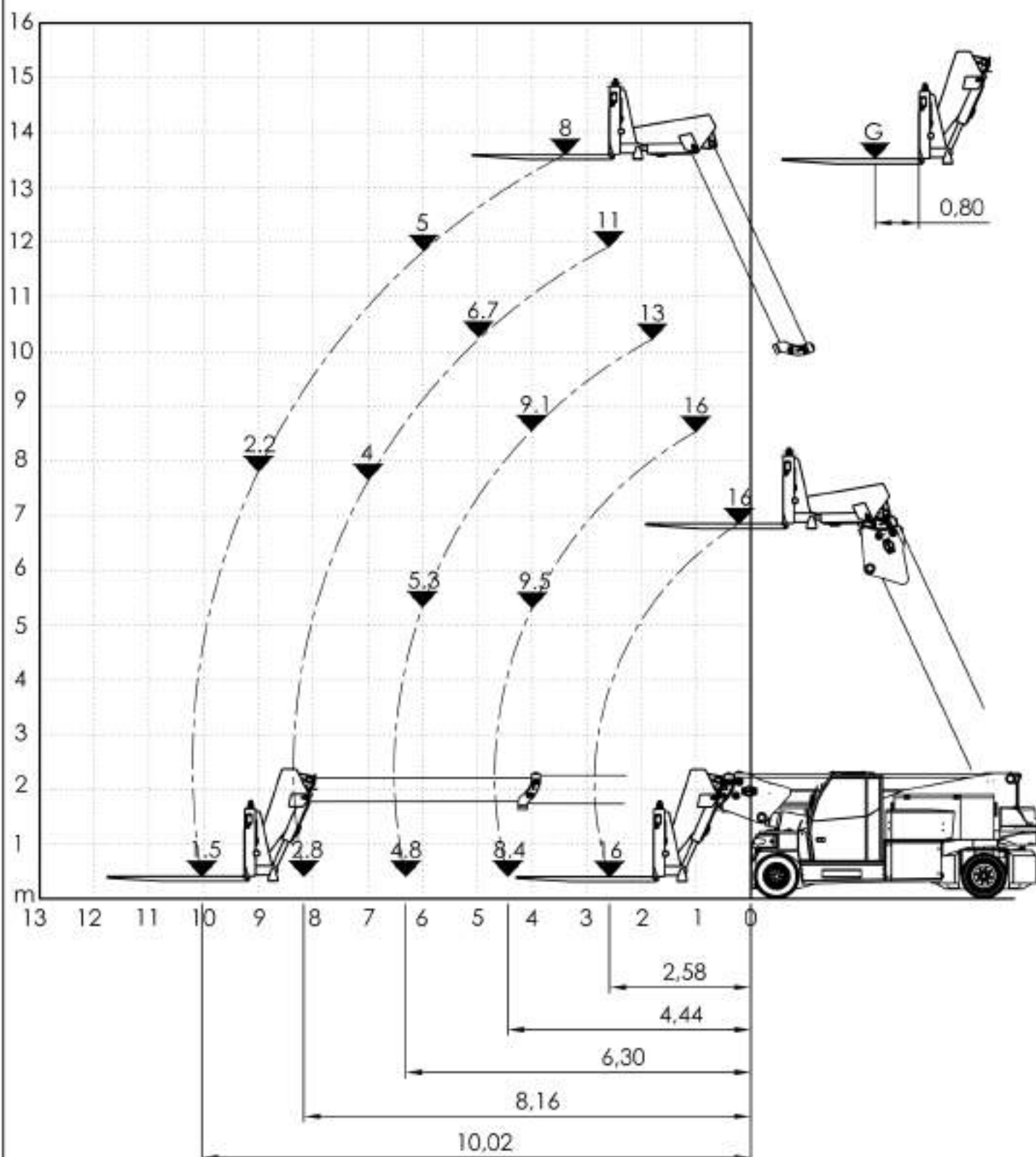

MC 400

Z1+Z2+Z3+Z4

Cod.: 090-DIA-03671
 Scala: 1:100

DIAGRAMMA DELLE PORTATE (t)
 CAPACITY DIAGRAM (t)
 TRAGLASTDIAGRAMM (t)
 LASTENDIAGRAM (t)
 TABLEAU DES CHARGES (t)
 DIAGRAMA DE LAS CARGAS (t)

JMG

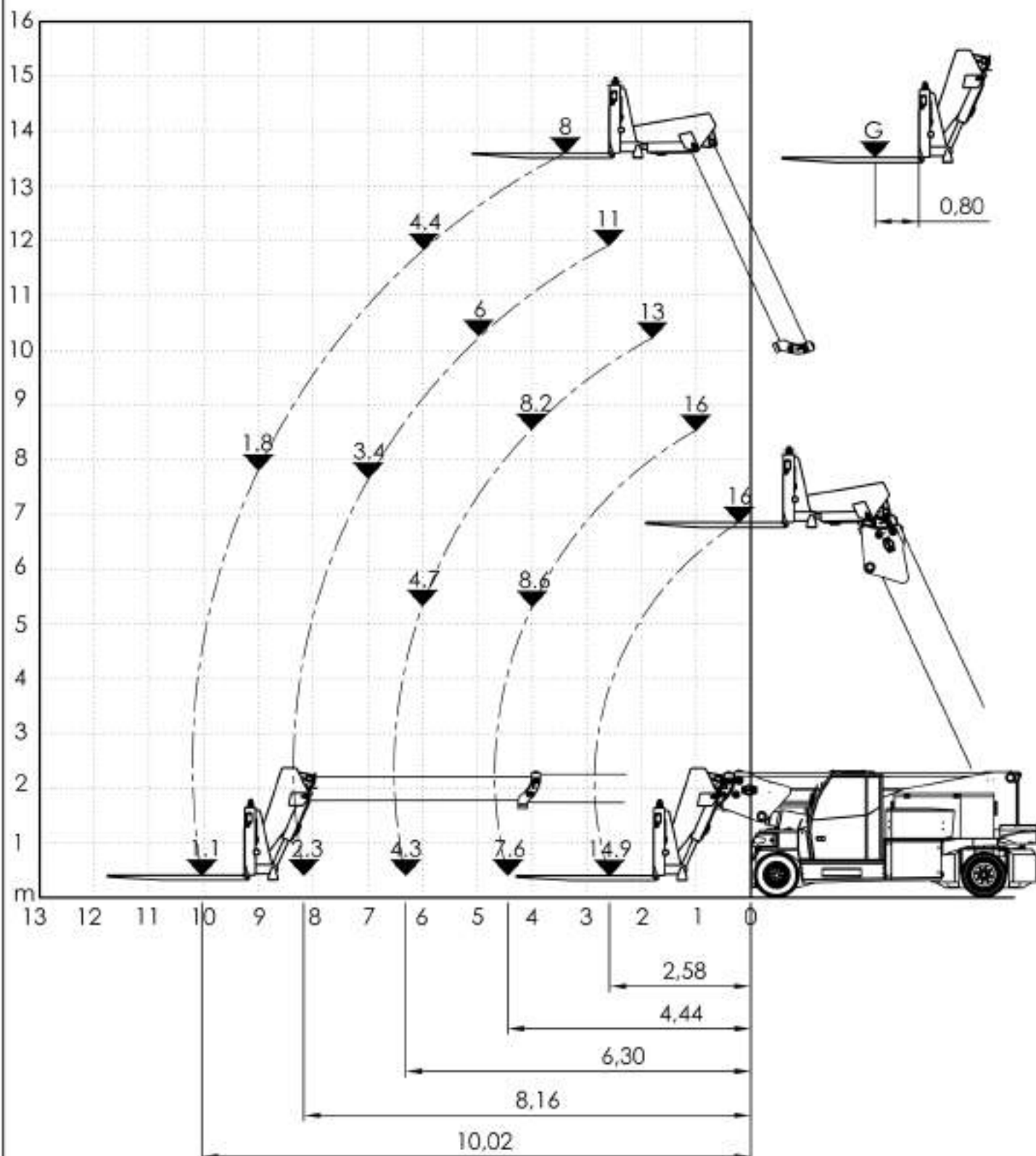

MC 400

Z1+Z2+Z3

Cod.: 090-DIA-03672

Scala: 1:100

DIAGRAMMA DELLE PORTATE (t)
 CAPACITY DIAGRAM (t)
 TRAGLASTDIAGRAMM (t)
 LASTENDIAGRAM (t)
 TABLEAU DES CHARGES (t)
 DIAGRAMA DE LAS CARGAS (t)

JMG

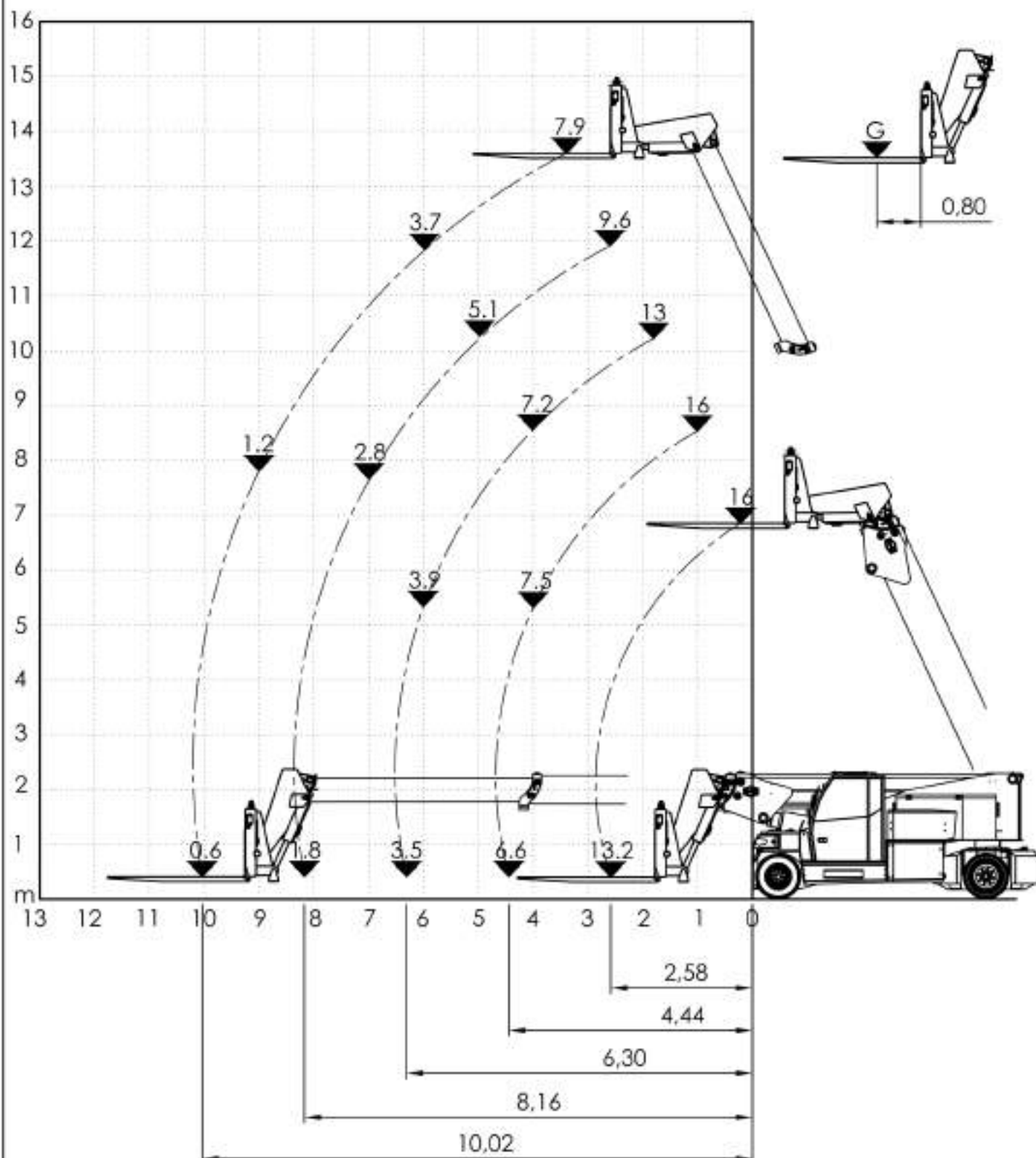

MC 400

Z1+Z2

Cod.: 090-DIA-03673
 Scala: 1:100

DIAGRAMMA DELLE PORTATE (t)
 CAPACITY DIAGRAM (t)
 TRAGLASTDIAGRAMM (t)
 LASTENDIAGRAM (t)
 TABLEAU DES CHARGES (t)
 DIAGRAMA DE LAS CARGAS (t)

JMG

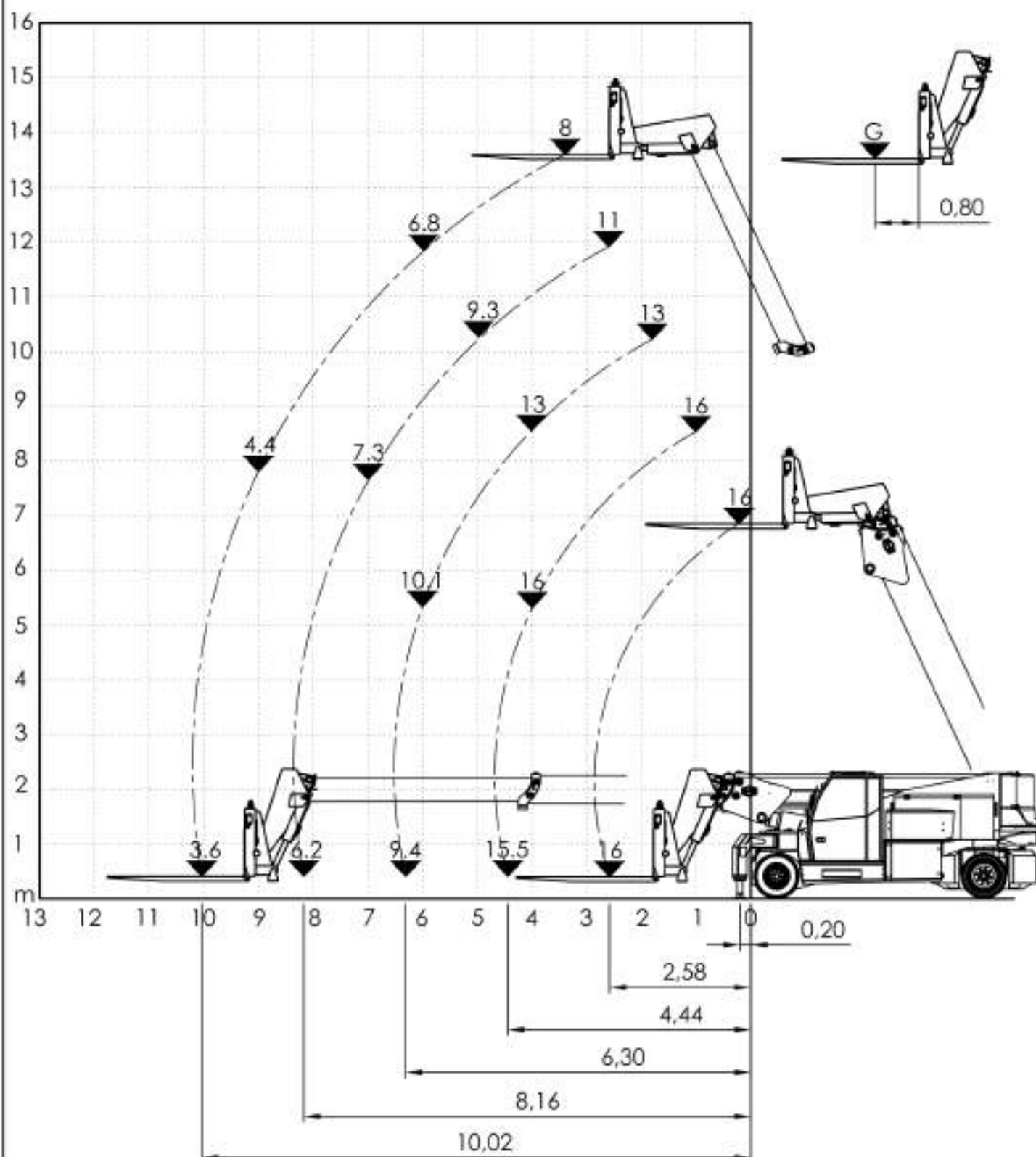

MC 400

ST 200 Z1+Z2+Z3+Z4+Z5+Z6

Cod.: 090-DIA-03674
 Scala: 1:100

DIAGRAMMA DELLE PORTATE (t)
 CAPACITY DIAGRAM (t)
 TRAGLASTDIAGRAMM (t)
 LASTENDIAGRAM (t)
 TABLEAU DES CHARGES (t)
 DIAGRAMA DE LAS CARGAS (t)

JMG

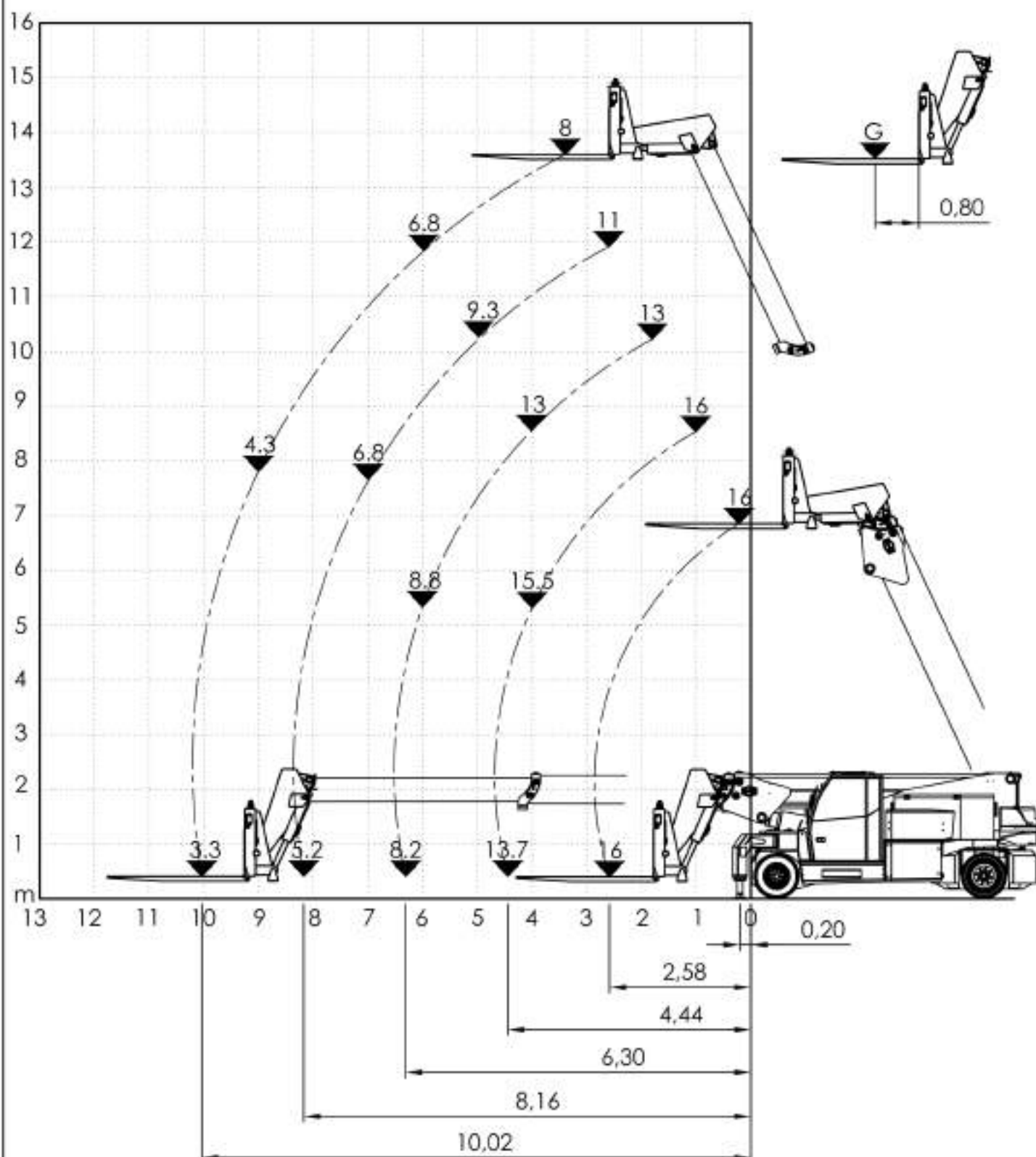

MC 400

ST 200 Z1+Z2+Z3+Z4

Cod.: 090-DIA-03675
 Scala: 1:100

DIAGRAMMA DELLE PORTATE (t)
 CAPACITY DIAGRAM (t)
 TRAGLASTDIAGRAMM (t)
 LASTENDIAGRAM (t)
 TABLEAU DES CHARGES (t)
 DIAGRAMA DE LAS CARGAS (t)

JMG

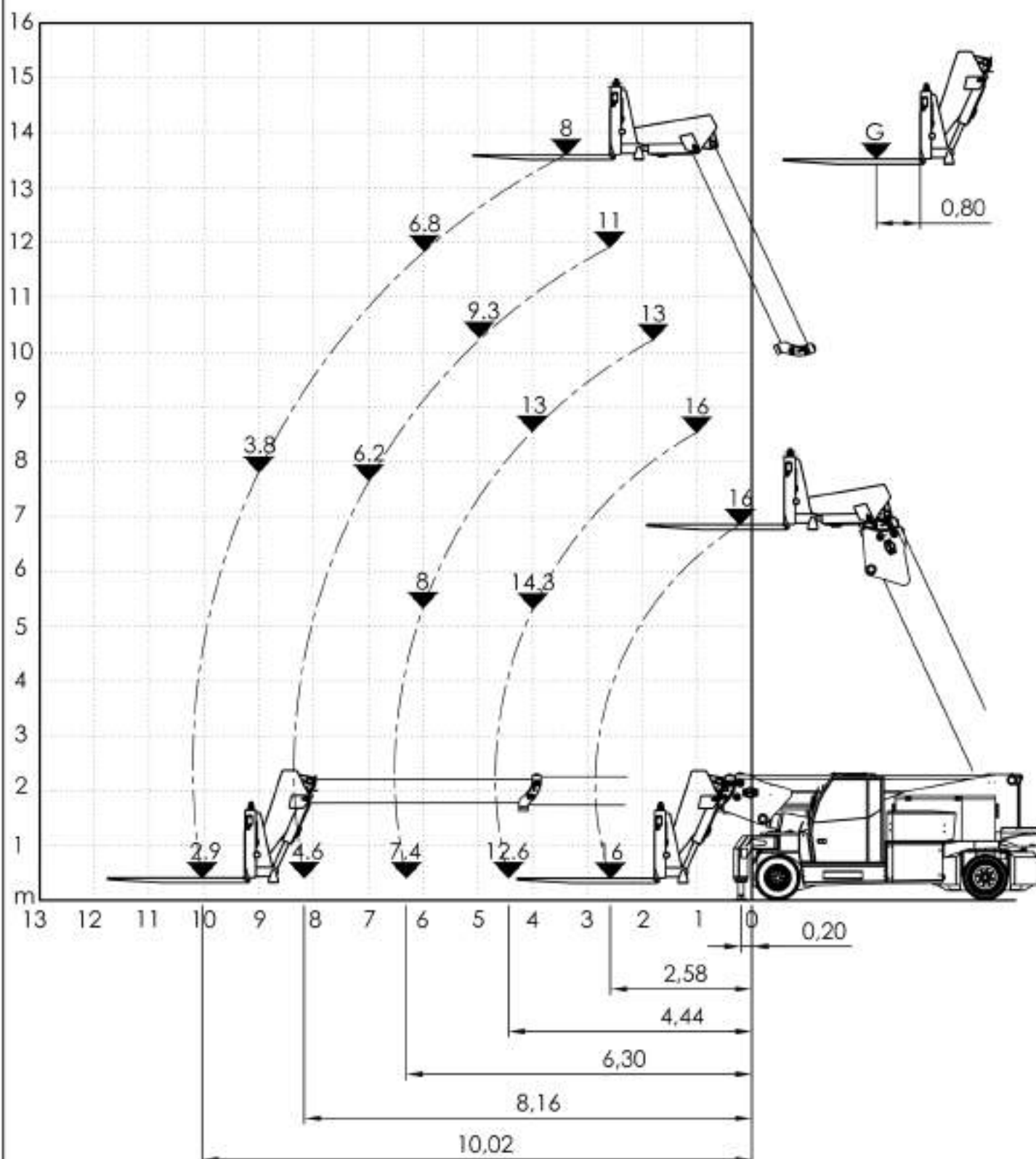

MC 400

ST 200 Z1+Z2+Z3

Cod.: 090-DIA-03676
 Scala: 1:100

DIAGRAMMA DELLE PORTATE (t)
 CAPACITY DIAGRAM (t)
 TRAGLASTDIAGRAMM (t)
 LASTENDIAGRAM (t)
 TABLEAU DES CHARGES (t)
 DIAGRAMA DE LAS CARGAS (t)

JMG

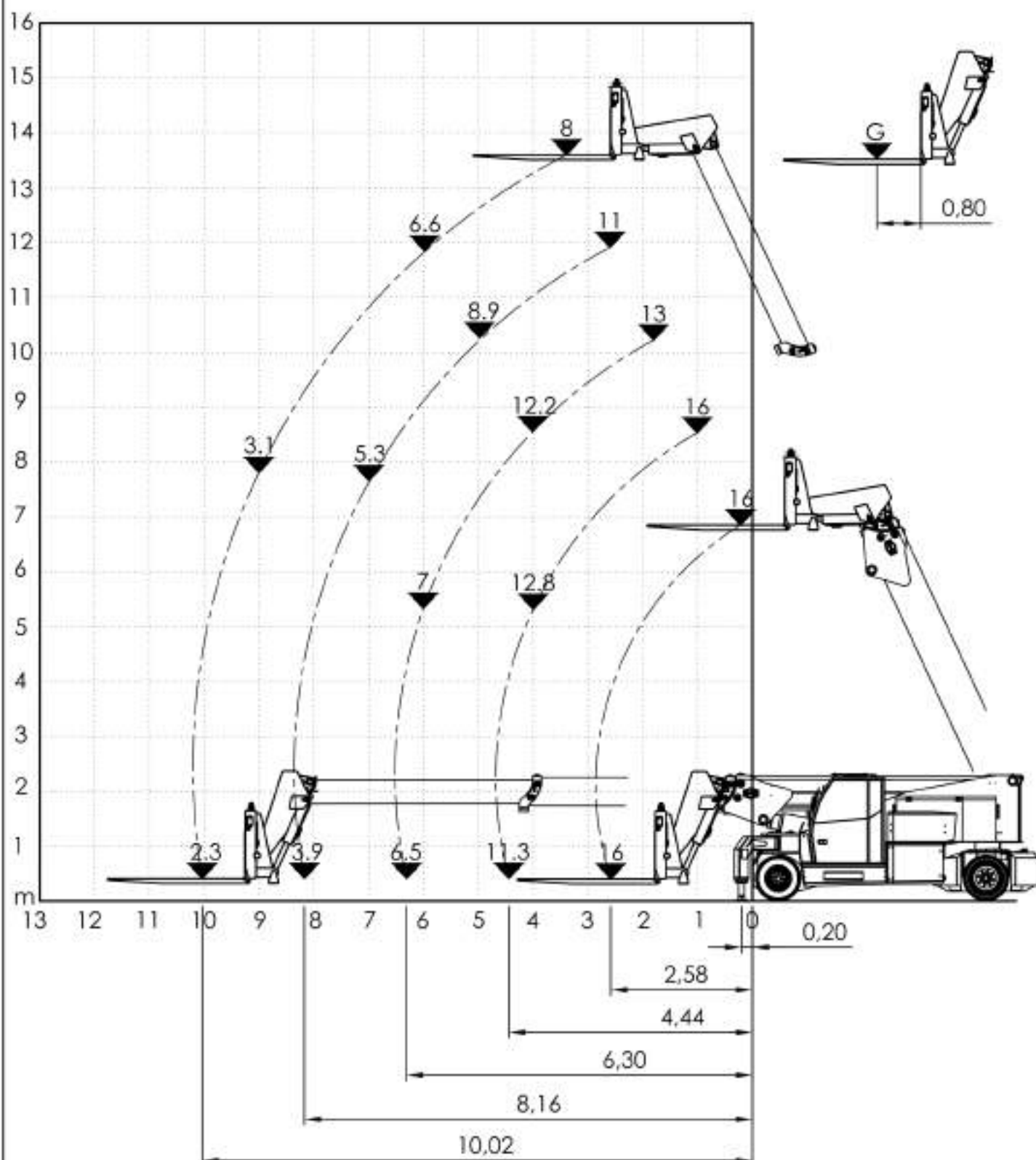

MC 400

ST 200 Z1+Z2

Cod.: 090-DIA-03677
 Scala: 1:100

DIAGRAMMA DELLE PORTATE (t)
 CAPACITY DIAGRAM (t)
 TRAGLASTDIAGRAMM (t)
 LASTENDIAGRAM (t)
 TABLEAU DES CHARGES (t)
 DIAGRAMA DE LAS CARGAS (t)

JMG

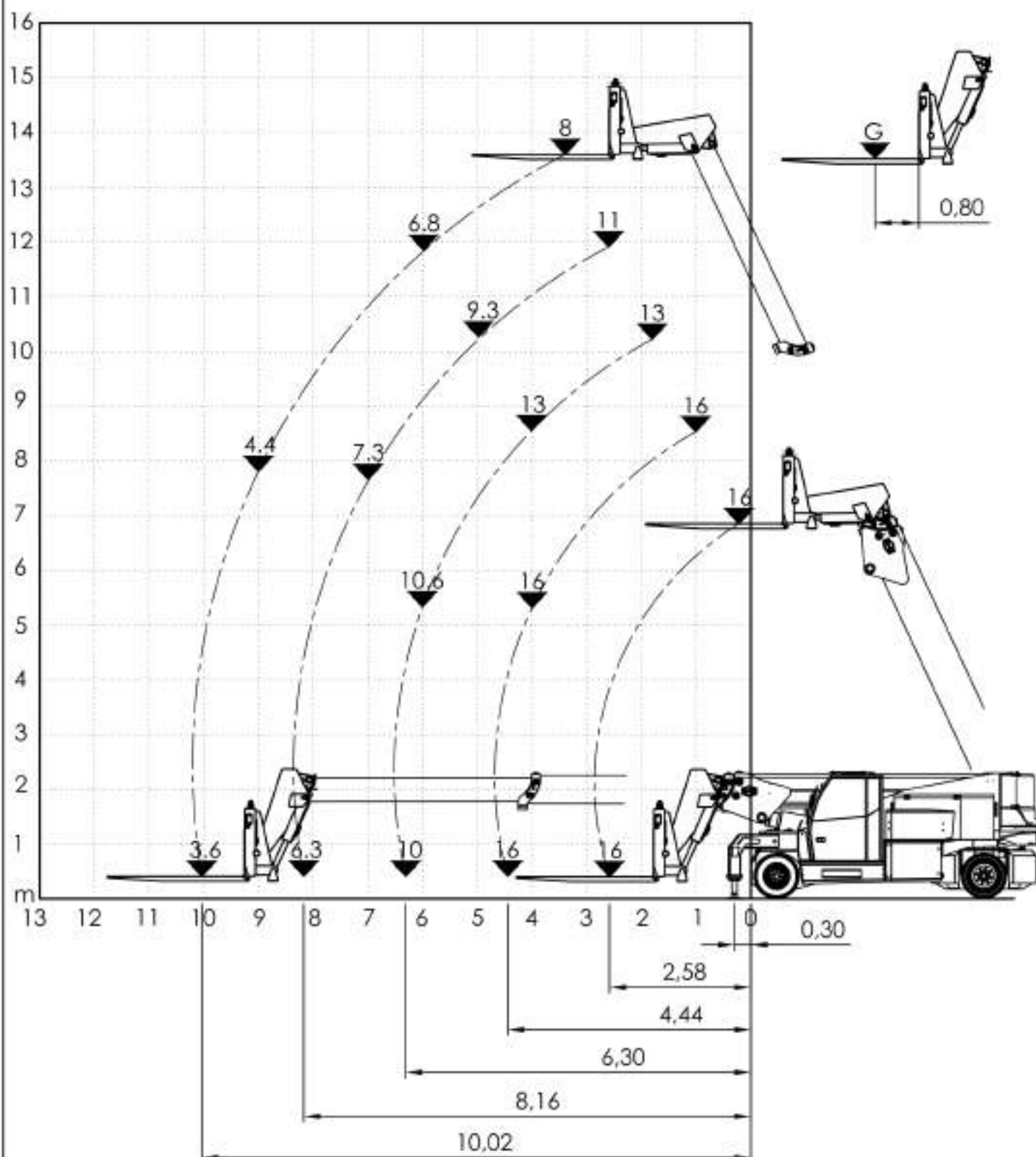

MC 400

ST 300 Z1+Z2+Z3+Z4+Z5+Z6

Cod.: 090-DIA-03678
 Scala: 1:100

DIAGRAMMA DELLE PORTATE (t)
 CAPACITY DIAGRAM (t)
 TRAGLASTDIAGRAMM (t)
 LASTENDIAGRAM (t)
 TABLEAU DES CHARGES (t)
 DIAGRAMA DE LAS CARGAS (t)

JMG

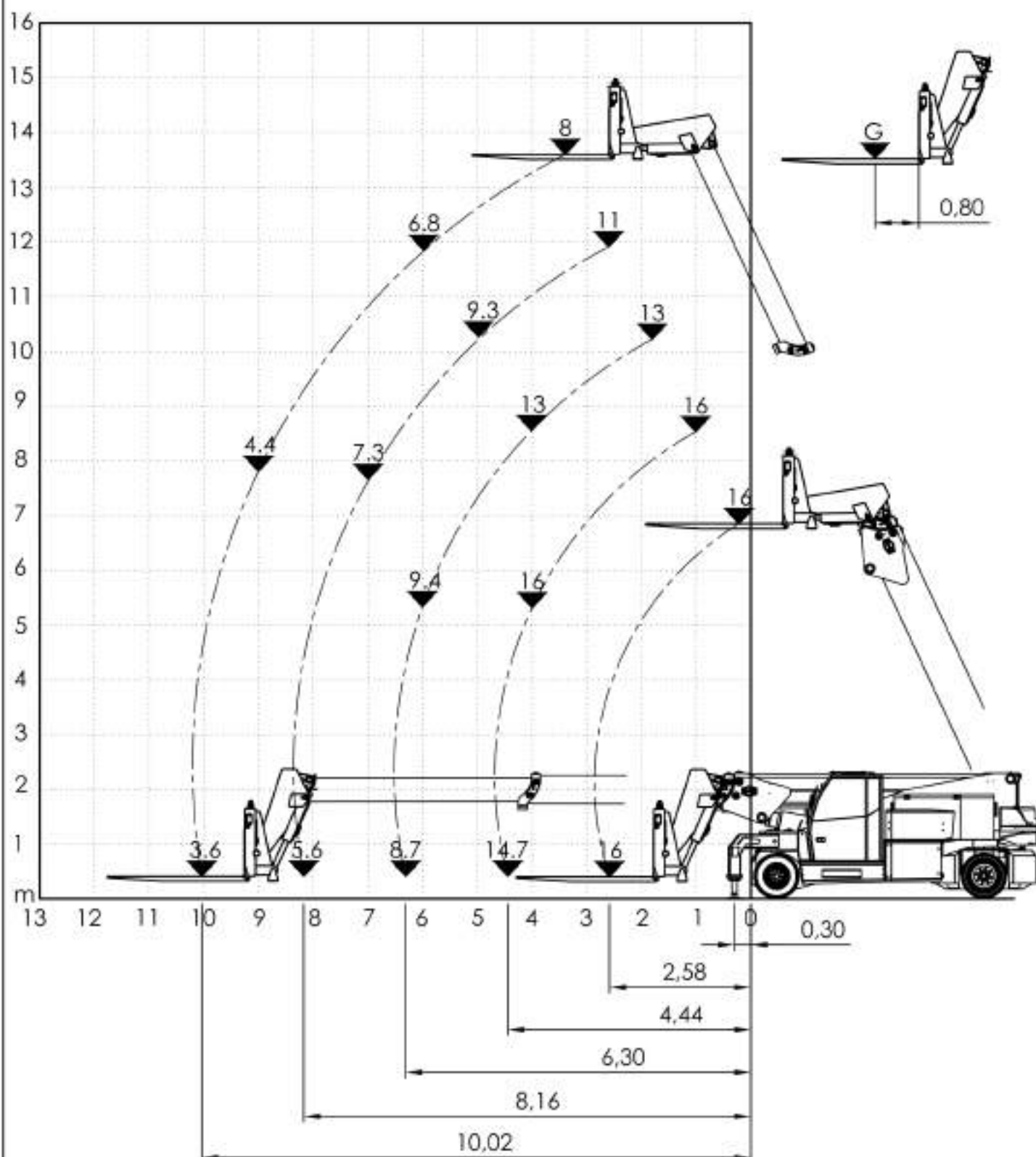

MC 400

ST 300 Z1+Z2+Z3+Z4

Cod.: 090-DIA-03679
 Scala: 1:100

DIAGRAMMA DELLE PORTATE (t)
 CAPACITY DIAGRAM (t)
 TRAGLASTDIAGRAMM (t)
 LASTENDIAGRAM (t)
 TABLEAU DES CHARGES (t)
 DIAGRAMA DE LAS CARGAS (t)

JMG

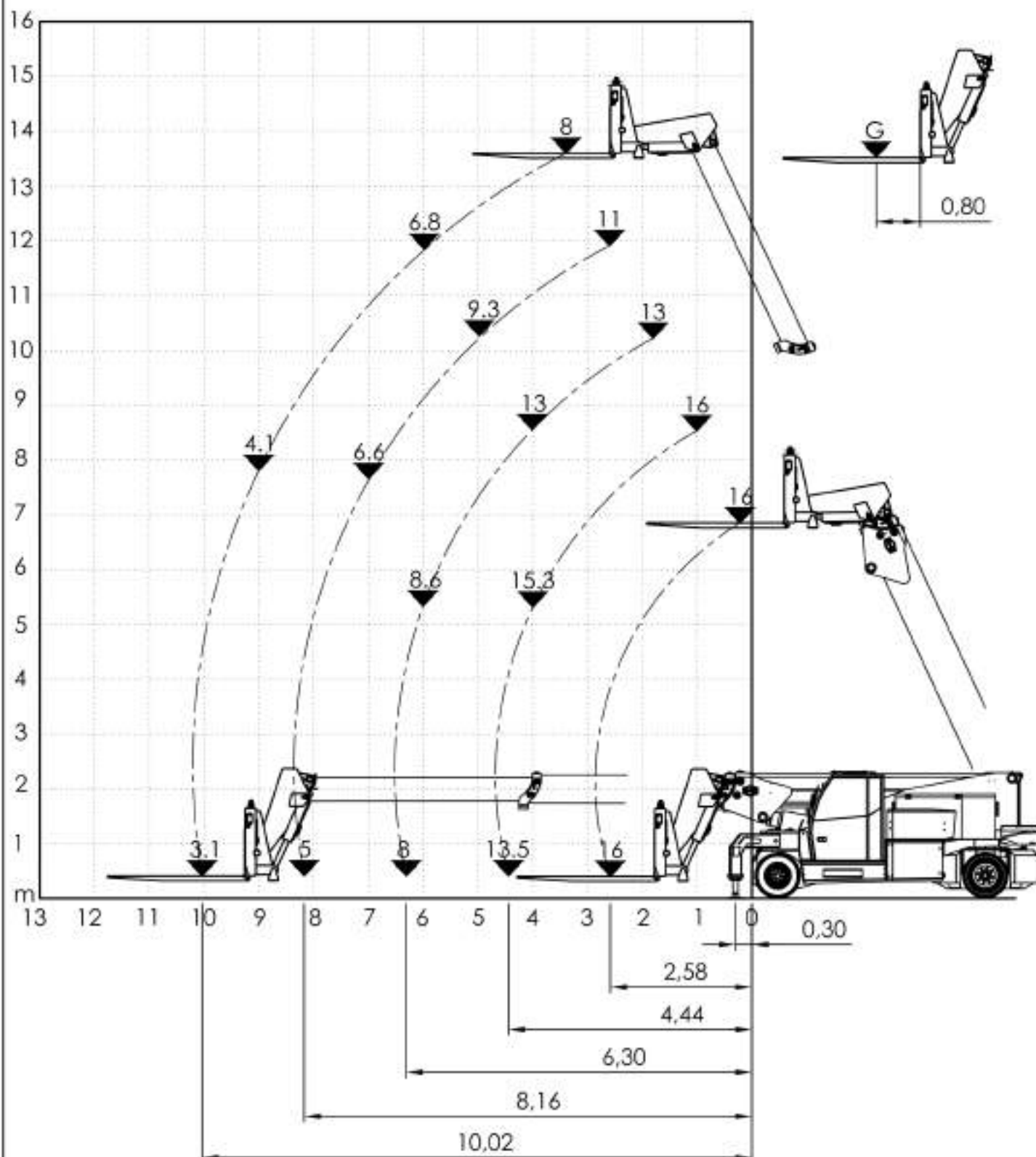

MC 400

ST 300 Z1+Z2+Z3

Cod.: 090-DIA-03680
 Scala: 1:100

DIAGRAMMA DELLE PORTATE (t)
 CAPACITY DIAGRAM (t)
 TRAGLASTDIAGRAMM (t)
 LASTENDIAGRAM (t)
 TABLEAU DES CHARGES (t)
 DIAGRAMA DE LAS CARGAS (t)

JMG

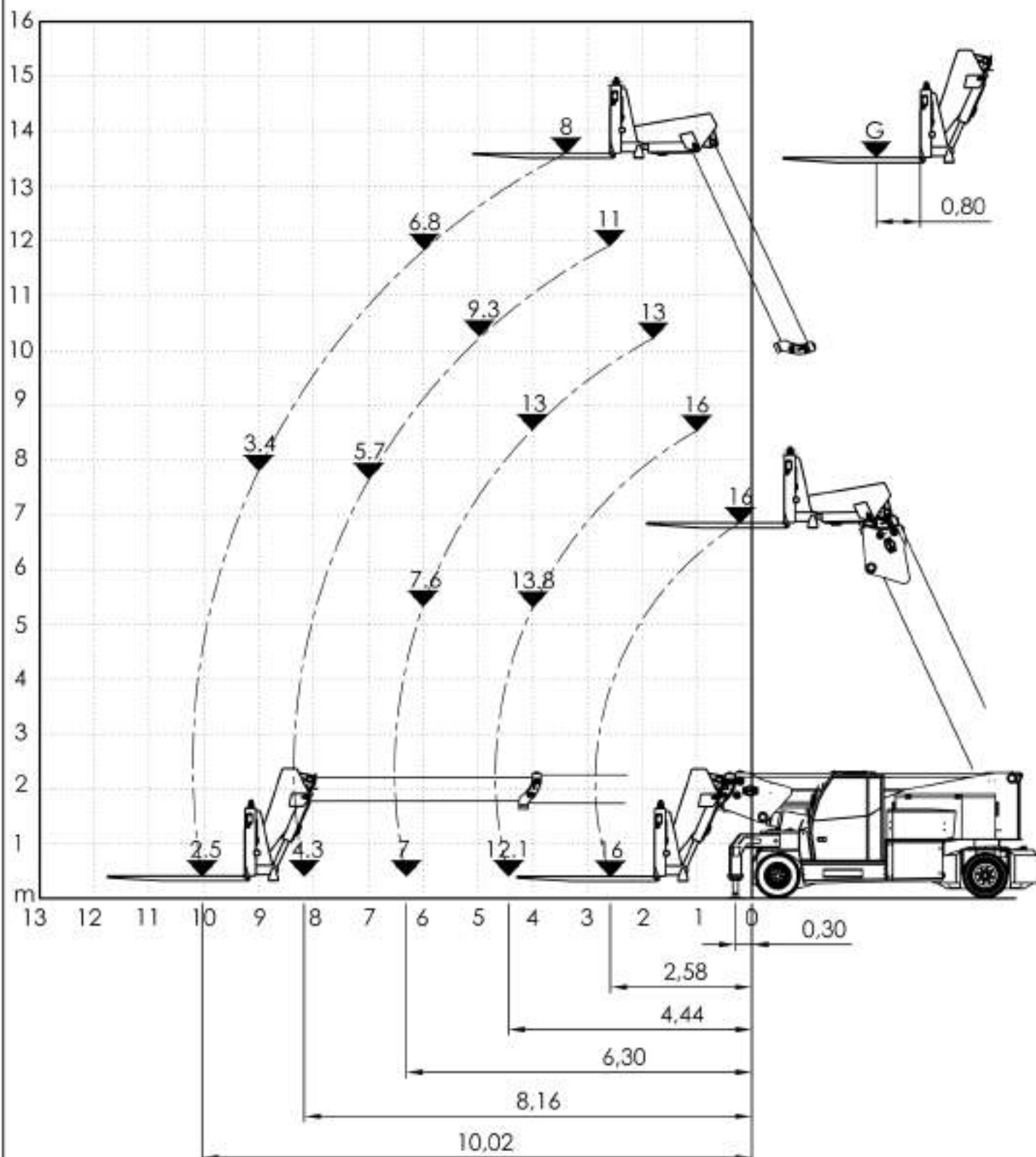

MC 400

ST 300 Z1+Z2

Cod.: 090-DIA-03681
 Scala: 1:100

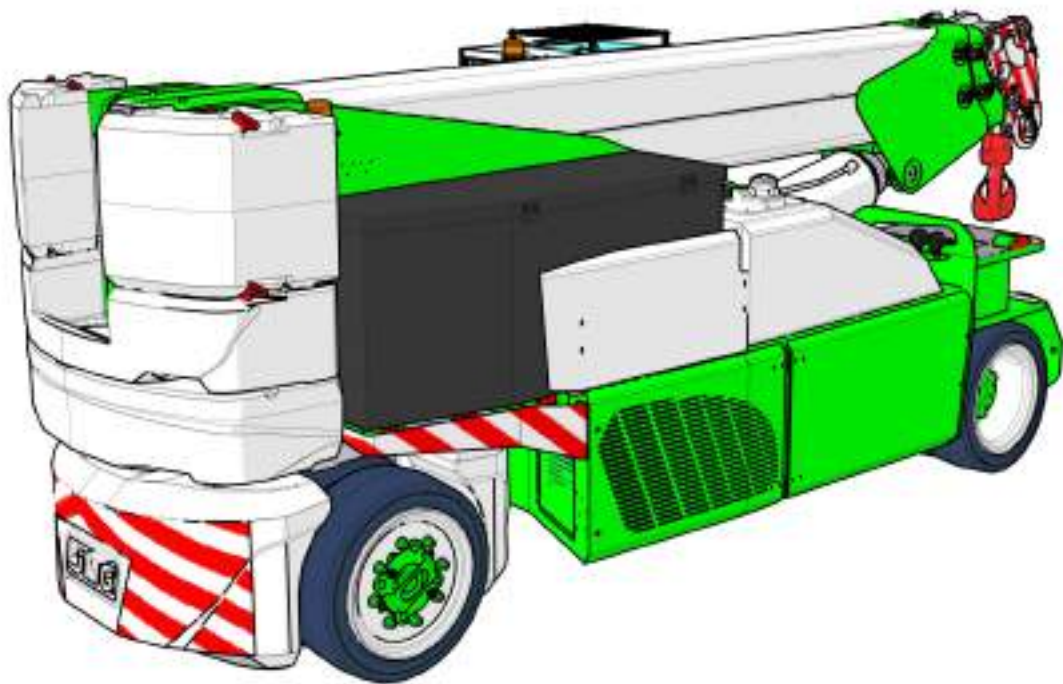

19.01.2026- REF. 1442 (DE)

JMG

JMG Cranes S.p.A.
Via Zuccherificio 2 - 29010 Sarnato (PC) - ITALY
Tel +39-0523-8486 - info@jmgcranes.it